

CAD FILE:

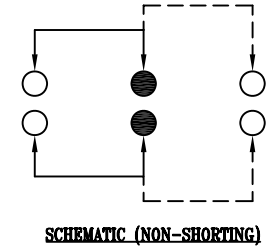
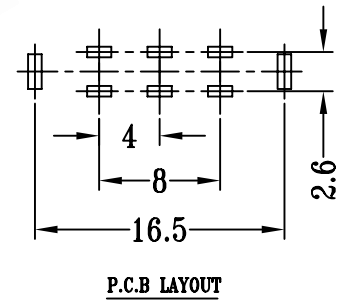
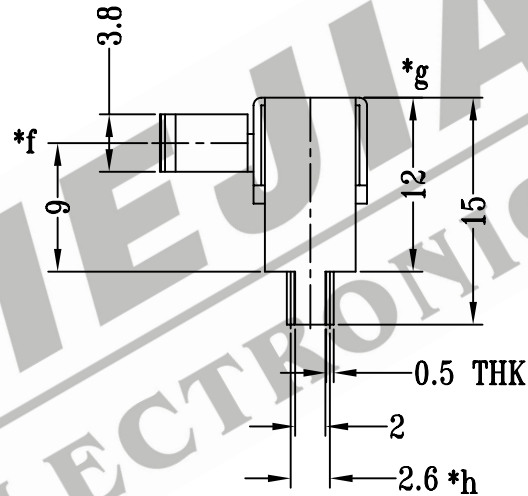
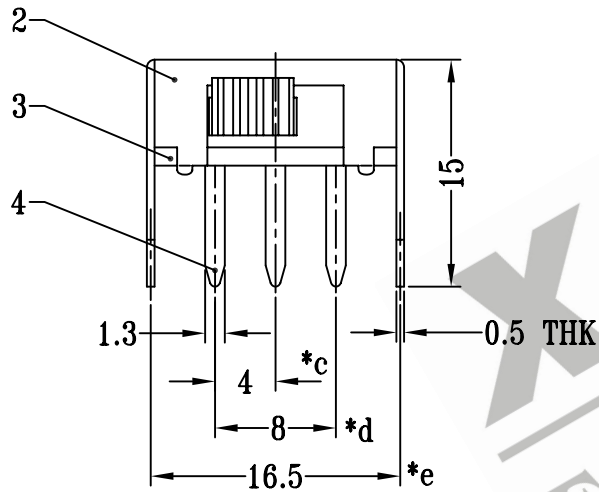
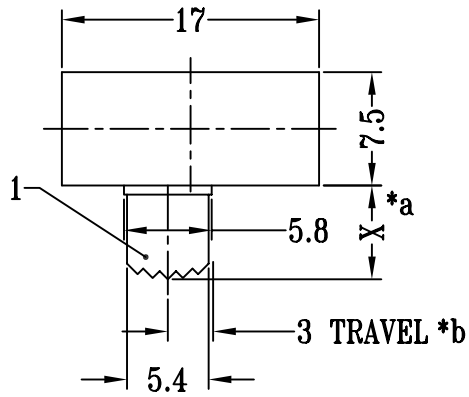

注:带\*表示关键尺寸(8个)

NO.	PART NAME	MATERIAL	Q'TY	FINISHING	TOLERANCE UNLESS SPECIFIED	SHENZHEN XIEJIA ELECTRONICS CO.,LTD.				
8										
7										
6	CONTACT	COPPER STRIP	2	Ag PLATED	WITHIN: 1.5±0.1mm	ISSUE	DATE	DESCRIPTIONS		APPD.
5	SPRING	STEEL WIRE	2	TEMPER	OVER : 1.5±0.2mm					
4	TERMINAL	BRASS STRIP	6	Ag PLATED OVER Ni PLATED	TITLE : HORIZONTAL SLIDE SWITCH		UNIT : MM	DRWG NO.: XJ-DR-SK22F10-00		
3	BASE	PHENOLIC RESIN	1	BLACK	MODEL: SK-22F10		SCALE: 2:1	DWN.	ZHOUYU	2005-2-6
2	FRAME	STEEL STRIP	1	Ni PLATED				CHK'D	FANGYING	2005-2-6
1	KNOB	POM	1	BLACK	ALL MATERIALS MUST BE COMPLIANT TO ROHS			APPD.	KANGXINAN	2005-2-6